

Raiders end CBA domination, lacrosse cruises to 15-1 record

The most successful baseball season in almost 15 years became even sweeter on Tuesday when the Red Raiders downed a long-standing nemesis in convincing fashion. Equaling the longest win streak in nine seasons with their fifth straight victory, the Raiders charged past Christian Brothers Academy in an 8-3 final.

After spotting the Brothers an early 1-0 lead, Fulton scored six of the next seven runs to improve to 11-6 overall and 6-3 in OHSL Freedom American play. And in the process the Raiders ended an eight season, 13 game stand of frustration against the boys in purple and gold with their first win over the Brothers since a 6-5 triumph in 2007. The win was especially gratifying given CBA's overall domination of the series that had seen the Brothers outscore Fulton 152-43 over the 13 game stand, an average score of 12-3.

But CBA's offense fell far short of that average on Tuesday as Bryce Guernsey scattered seven hits and five strikeouts to send the Brothers home at 7-9 overall and 4-6 in league play.

On the other side of the plate Adam Baldwin led a 10 hit Raider attack with a single and a home run to drive in three runs while Cody Green scored three runs and

reached base four times as he delivered two hits and drew a pair of walks. Koda LaBeef slapped a single and a double to bring home two more Raider runs and Charlie Alton added an RBI single to go with a double off the bat of Cole Cotton. Bryce Moore paced CBA with a pair of hits.

Fulton scored a single run in the bottom of the second inning and then added two more in the third to take the lead for good. CBA threatened with a run in the top of the fourth to make it 3-2, but that was as close as they could come as the Raiders added three runs in the fifth inning and a two run sixth put the game away.

Coach Harvey's crew will have little time to savor the victory, however, as they host Central Square today and Jordan-Elbridge on Thursday in a pair of 4:30 pm starts.

Lady Raiders overwhelm Clinton

It was a night to honor the seniors, but the underclassmen had their say on Tuesday when the Lady Raider lacrosse team closed the best regular season in school history in dominating fashion. Just hours after making their way into the New York State Class B rankings, Fulton routed Clinton 20-5 to head into the upcoming Section III playoffs

(continued on page 4)

This week in Red Raider sports

Today: JV baseball @ C.Square (4:30); V baseball vs. C.Square (4:30); Boys lax @ ES-M (JV-4:30/V-6:30)

Thurs. May 19: V baseball vs. J-E (4:30)

Fri. May 20: JV girls lax vs. Homer (4:30); Softball @ J-D (4:30)

Sat. May 21: Track @ C-NS Invitational (10 am)



Battle of the Athletes set for June 8

Sign-ups are currently underway for the 2016 Battle of the Athletes. The event will take place on Wednesday, June 8, and is open to any JV or varsity athlete. The cost is still just \$1, which includes a team t-shirt.

Sign up with any physical education teacher or with Mr. Rothrock in room 209. Don't delay, as the slots will fill up fast.

Volunteers needed for Fairgrieve AR celebrations

Volunteers are needed for the Fairgrieve Elementary School Accelerated Reader Celebration on Wednesday, June 15. Earn community service hours and have some fun in the process. The two sessions are from 10:30-11:30 am and from 1:45 to 2:45 pm.

Interested students should contact Mrs. Senecal at Fairgrieve via school e-mail at: bsenecal@fulton.cnyric.org or leave your name with Mr. Senecal in room 118.

Football meeting May 25

There will be a meeting for anyone interested in playing football this fall on Wednesday, May 25 after school in Coach Rothrock's room 209. Camps, summer schedules and other important dates will be discussed, so all football players should plan on attending.

This Saturday!

GRR Science Club
GRR Environmental Club

SPRING CLEAN-UP

SATURDAY Morning

May 21st ... 9 am – Noon ... Meet at the Flagpole









It's Painless,
It's Community Service
It's FUN w/ Friends !
It's ... School Pride

Dorm life vs. home life: the pros and cons

Advantages and Disadvantages of Living in a Dorm

Advantages:

1. Meal Plan
2. No Utility Bills
3. Social Opportunities
4. Distance
5. Get to Know Other Students
6. Easy to Find Study Partners
7. A Sense of Responsibility and Freedom
8. Good Security and Maintenance

Disadvantages:

1. Little Privacy
2. Strict Rules
3. Noise
4. Lack of Cozy Home Feeling
5. Boring Life Routine
6. Cost
7. Might Not Like Roommate

Advantages and Disadvantages of Living at Home During College

Advantages:

1. Cost
2. Get Sick Less
3. Fewer Distractions
4. Home Cooked Balanced Meals
5. Adjustment is Easier
6. Avoid the "Freshman 15" weight gain
7. Emotional Support

Disadvantages:

1. Commuting
2. Missing Social Events
3. Missing the Feeling of Freedom
4. Harder to Make Friends
5. Stress

compiled by Kim Rombough

Welcome to the future: introducing cyborg lenses

Everyone has a secret part of them wishing they were a superhero, cyborg, or some other fantasy creature. Now Google is helping to make some of these dreams a reality, just not quite yet. Google has just patented cyborg lenses, which would be injected into the eyeball. While some are shrieking in their seats reading this, I know others are thinking of when they will be able to sign up for human trials.

The idea is to be able to eliminate the need for glasses or contacts. The lenses, figuratively speaking, would be able to help those with eye problems such as myopia, hyperopia, and astigmatism. The lenses could go even farther than this though, being able to capture photo and video while also connecting to wireless devices. The issue at hand here is security. If your eye can connect to wireless devices then surely someone can hack into your eye, ultimately putting yourself at risk. People would be able to see all that you see, which has blackmail written all over it.

Reasons such as this are why these fascinating cyborg-like lenses are merely a patent at the time. Not that it would not be extremely cool for it to not be something of today's common man. For now

glasses and contacts will have to do the trick. *By Kassidy Bowering*

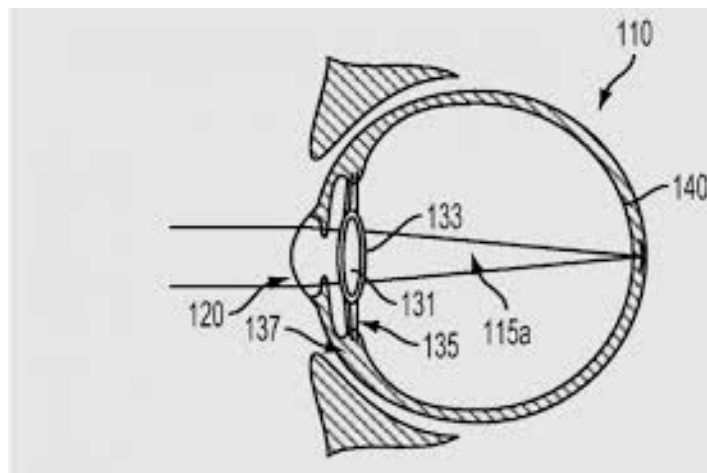

**When you want to
look your best!**

**Book now for the
prom & dinner dance**

Your full service salon!

Reflections

-THE- Salon & More

608 South 4th Street-Fulton
(across from McDonalds)

Call for an appointment today!

Phone: 592-4415

*Proud 25 Year sponsor
of GRB Journalism*

Opinion

Managing the mess: it starts with addressing it

By Mitch Nelson



Everyone's life is a mess, and whether they believe it or not the best way to overcome the mess is to address it, not avoid it. Most people have the ability to be a "hot mess" when their life is in disarray. Technically, a hot mess is when someone can continue to function through everyday life and can make it look like they are okay when their life is actually crumbling around them. The lucky people are the ones who happen to be in between messes, but just know, your next mess is only one wrong decision away. People may go 6-8 months where they are happy and stress free, but no one makes it a lifetime without a mess beating them down.

The good news for people going through a mess is that it's not just you, someone else always has a bigger mess than you in their life. More good news for people in messes is that the mess of life is what brings us together in life.

When a person sees another person making a bad decision or spinning down the wrong path, before being critical it is important to remember that you are a mess too! We must be students, not critics of people's lives, because when you hear the story of someone's mess you see them differently, you feel for them, and the criticism goes away. Therefore, why be critical before you know what they are going through?

Everyone sees a mess when they look in the mirror, whether it is a past mess or a current mess. This is why it is important to be careful of how we criticize other people, because someday you might encounter a mess that you cannot get out of on your own and this will be a reminder of how much we really need each other. If someone has ever stepped into your life at a time of need and helped you pull out of a mess it is a reminder that that is supposed to be our

response to people when their life is a mess.

Everyone falls short of who they want to be in life at some point, and every person will make a mistake in life. If you are there for someone else in their time of need they will turn around and do the same for another, and this is life. As The Bible says, "Awareness of our messes awakens us to something outside of us to which we are accountable." Take that as you will.

What's happening at G. Ray Bodley High School?

Senior Dinner Dance tickets are now available for \$45 apiece. See Mr. McCarten in room 222 for details and to purchase tickets. Don't wait too long, the big day is rapidly approaching.

Looking for a **summer job**? Oswego County Workforce is now accepting applications for their Summer Youth Employment Program. Stop by the counseling office for an application.

Registration packets for **summer driver education** are now available in the counseling office. Students who reach their 16th birthday by July 5 can register for the summer session, however current seniors are not eligible.

Bodley Bash 2016 is coming! Mark Monday, June 13 for this year's bash. Kickball teams are currently registering. There is a 10 player maximum. See Coach Stalker to sign up. Other events include bounce houses, food, music, yard games and more.

What's for lunch?

Today: Cheese pizza, broccoli, butternut squash, banana
Thursday: Turkey and cheese melt on soft pretzel, potato wedges, corn and pears

WALDRON'S FURNITURE
EST. 1963

SPECIALIZING IN:

Sofas, Chairs, Recliners, Sleepers, Ther-A-Pedic
 Bedding-all sizes, Tables & Chairs, Hutches,
 Bedroom Furniture, Glider Rockers, End Tables,
 Coffee Tables, Lamps, etc., etc.

• Layaways • Credit Terms

53RD
ANNIVERSARY SALE

\$53 OFF A \$500 OR MORE PURCHASE

Best Home Furnishings 75 Models On Display

ASHLEY
 FURNITURE, BEDDING, ETC.

LANCER



VISA



Bowen's Corners, Rte. 176 S. • 592-7481

Hours: Monday thru Friday 10:00 a.m. to 5:00 p.m. • Saturday 10:00 a.m. to 2



We won't be undersold
 facebook.com/WaldronsFurniture

Raider Sports

Carroll tops 100 point mark in lacrosse rout

(from page 1)

at 15-1.

A 14 goal first half set the tone for the night as the #24 ranked Red Raider girls were just too much for the Warriors to handle. Sophomore Hailey Carroll surpassed 70 goals and 100 points for the season with eight goals and two assists while fellow tenth grader Mckenna Chesbro struck five times with three assists to burst past the 50 goal plateau. Carroll now has 76 goals and 37 as-

sists for 103 points and Chesbro has found the back of the opposing goal on 53 occasions while freshman Keara Patterson scored twice with three assists and has 97 points on the season.

Sophomores Jordan Coulon and Mallori Kitts contributed two goals and an assist each and senior Taylor Kesterke rounded out the scoring with a solo marker. Senior Kaylin Pafumi finished with eight saves for the

Raiders, who will now await the upcoming sectional seeding meeting where they are a likely #2 seed for the Section III Tournament. Pafumi and Kesterke were honored along with Class of 2016 teammates Gina Babcock, Olivia Coakley, Joanna Pappalardo and Paige Noel.

Blythe Owens scored three times to pace the Warriors, who dropped to 7-8 in defeat.

Raiders seek playoff momentum tonight at ES-M

The Raider lacrosse team is prepared to take on the East Syracuse-Minoa Spartans tonight at 6:30 in the regular season finale. The Raiders are coming off a tough loss against Jordan-Elbridge where they were able to battle back within one goal, but ultimately could not finish the job. ES-M is on a four game losing streak, and since their last win came against Oswego on May 3, they are itching for a victory.

Last season the ESM-Fulton matchup ended in two losses for Fulton in a 12-11 thriller and a 17-9 Spartan runaway. ES-M is a big team with a lot of strong players, including all-state football player Jeremy Perry. The 6 foot 1 inch senior weighs in at 240 pounds and overpowers his defender on his way to the cage. Perry has used this method to rack up 15 goals this season, a considerable drop from the 33 of his 2015 season, but he is still a valuable asset to the team.

Fulton has an answer for this behemoth

though, Tyler Shaw, better known as "Slaps," matches the size of Perry, and with his ability to take the ball out of the air no matter where it is it will give him an edge over Perry on the Raiders defensive end.

Connor Smith is another attackman for the Spartans, and since he is leading the team with 31 goals the Raiders will be placing senior defenseman Robbie Pollock on him to make sure he cannot get his hands free to get a shot.

The Raiders have made a switch on their man up squad, placing Shaw at the top cor-

ner, allowing him to rip shots with his long pole, which goalies are unable to track. Shaw has eight goals on the season, all against Jordan-Elbridge, with three in the first game and five in the second. This move is sure to aid the Raiders in a victory over the Spartans, so head up to Spartan stadium at 6:30 tonight to support the Raiders in their final regular season game as they seek a .500 regular season and much needed momentum heading into the upcoming Section III Tournament.

By Mitch Nelson

Bodley Bash set for Monday, June 13

The annual Bodley Bash will take place on Monday, June 13th from 3-5 pm. The Bodley Bash is a fun, end of the year event that is full of games and laughs. The annual kickball tournament is the big event taking place during the Bash. Signups for the kickball teams are right now! See Coach Stalker for a sign up sheet, there is a 10 person max to each team. Teachers are allowed to play on the teams as well. Sign up fast before all of the team spots are taken.

Also at the Bodley bash will be bounce houses, food, yard games, music run by former student Kyle Buck and many more fun activities. The cost is free for all G. Ray Bodley students. The Bodley Bash is just a way to celebrate the end of the school year in a fun way.

By Nicole Hansen

**Send your
pictures of
the Red Raiders
in action**

theraider@fulton.cnyric.org

*** Spring sports ***

Clubs

*** GRB Music Dept. ***

Candids

Going someplace cool?

Take

RaiderNet Daily

with you and get your picture taken for next year's Fultonian Yearbook feature

**"Where in the world
is The Raider?"**

What class are you most nervous about?



"Global Environment."

Megan McClintock



"Global Environment."

Jacob Bailey



"The cosmology program."

Keysha Rojas



"My study hall."

Keegan Condon

Meteorology and you

Today:



Sun and clouds

62°

Average: 70°
Record: 90° (1962)

Tonight:



Clear skies

40°

Average: 47°
Record: 30° (1983)

Tomorrow:



Sun and clouds

65°

Average: 70°
Record: 92° (1971)

By Carson Metcalf



Congratulations to Carson Metcalf--SUNY Oswego Class of 2016!

Carson Metcalf is a former GRB student and recent SUNY Oswego Meteorology graduate. Look for his daily weather forecasts for Fulton on RaiderNet Daily.